

# STORM CASE®

Defy the Elements®

# iM2600



Press & Pull latches hold fast even under duress, yet open effortlessly.

Permanently attached Vortex™ valve automatically adjusts air pressure without letting in water.

Add the security of your own padlock to unbreakable, molded-in hasps.

The unique hinges with feet hold fast under impact and create a flat surface for upright stability.

Double-layered, soft-grip handles combine strength with long lasting comfort.

A lifetime guarantee ensures your Storm Case will outlast every situation.

Molded-in stacking ribs provide no-slip stability for multiple case stacking during storage or transport.

Storm Cases are designed to transport and protect your valuables even under the most adverse conditions.



#### Dimensions:

Exterior Dimensions (LxWxH)  
21.2 x 16.0 x 8.3 in.  
538 x 406 x 211 mm

Interior Dimensions\* (LxWxH)  
20.0 x 14.0 x 7.7 in.

508 x 356 x 196 mm

\*Total height shown; includes lid depth of two inches.

WEIGHT (EMPTY): 8.5 lbs/3.9 kg

#### FEATURES:

- Two Press & Pull Latches
- Double-layered, Soft-grip Handle
- Two Padlockable Hasps
- Vortex™ Valve
- Flush Powerful Hinges
- Lightweight Strong HPX® Resin
- Watertight
- Guaranteed For Life

#### COLORS:

Black, Yellow, Gray, Orange, or Olive Drab

#### INTERIOR FOAM:

Multilayer Cubed Foam or No Foam

#### STANDARD OPTIONS:

- Bezel Kit
- Manual Purge Valve
- Lid Stays
- Padded Divider Set
- Lock
- Shoulder Strap

#### CUSTOMIZED OPTIONS:

- Custom Foam
- Label (no label, custom labels)
- Custom Colors
- Molded-in 3D Graphics
- Foil Stamping



# The Storm Case Lineup



## Storm outpowers the competition.

Feature	Competition	Storm Case	Storm Case Advantage
Case Material	<ul style="list-style-type: none"> <li>• Polypropylene or ABS</li> </ul>	<ul style="list-style-type: none"> <li>• HPX High Performance Resin</li> </ul>	<ul style="list-style-type: none"> <li>• Better Impact Resistance</li> </ul>
Latches	<ul style="list-style-type: none"> <li>• Narrow "Knuckle Buster" Design</li> <li>• May Pop Open When Dropped</li> </ul>	<ul style="list-style-type: none"> <li>• Press &amp; Pull Operation with Extra Strength Wide Design</li> <li>• Won't Pop Open When Dropped</li> </ul>	<ul style="list-style-type: none"> <li>• Pain Free Latch Operation That's Twice as Strong</li> <li>• More Secure Case Closure</li> </ul>
Purge Valve	<ul style="list-style-type: none"> <li>• Manual Pressure Adjustment</li> <li>• Valve Screws Out (Could get lost)</li> </ul>	<ul style="list-style-type: none"> <li>• Vortex Valve</li> <li>• Valve Won't Fall Out</li> </ul>	<ul style="list-style-type: none"> <li>• Automatically Adjusts to Changing Environments</li> <li>• No Lost Valves</li> </ul>
Carry Handle	<ul style="list-style-type: none"> <li>• Hard, One-piece Construction or Thinly Padded with Harder Rubber</li> </ul>	<ul style="list-style-type: none"> <li>• Durable Inside Core with Soft Overlay</li> </ul>	<ul style="list-style-type: none"> <li>• More Comfortable to Carry</li> </ul>
Nameplate Area	<ul style="list-style-type: none"> <li>• Adhesive Labels</li> </ul>	<ul style="list-style-type: none"> <li>• Adhesive Labels</li> <li>• Custom 3-D Logo Option</li> </ul>	<ul style="list-style-type: none"> <li>• Easy Customization</li> <li>• Permanent, Molded-In Logos That Can't Fall Off</li> </ul>
Cubed Foam System	<ul style="list-style-type: none"> <li>• Single Layer of Cubed Foam</li> </ul>	<ul style="list-style-type: none"> <li>• Multilayer Cubed Foam</li> </ul>	<ul style="list-style-type: none"> <li>• Highly Customizable to Your Individual Needs</li> </ul>
Panel Mount System	<ul style="list-style-type: none"> <li>• Plastic Frame</li> <li>• Screwed to Interior, Variable Height</li> </ul>	<ul style="list-style-type: none"> <li>• Extruded Aluminum Rails with Molded Corner Pieces</li> <li>• Watertight, Sealed Rivet Attachment for Custom Fit</li> </ul>	<ul style="list-style-type: none"> <li>• Stronger Panel Mount Construction</li> <li>• Permanent, More Secure Panel Attachment</li> </ul>

## Life is an endurance test—so each Storm Case passes extreme testing requirements.

Test	Specifications Met	Description
Drop Test	FED-STD-101C, Method 5007.1, Paragraph 6.3, Procedure A, Level A.	A series of 26 drops, one on each corner, edge, face, from 19" to 30", depending on the gross weight of the case with loads of 15 lbs to 70 lbs (depending on case size).
Falling Dart Impact	ATA 300, Category I, "General Requirements for Category I and II Reusable Containers"	A dart weighing 13.22 lbs with a 1.25" hemispherical end was dropped on each case from 19.68".
Vibration (loose cargo)	FED-STD-101C, Method 5019	Each case was vibrated for 20 minutes per axis. 1-inch peak to peak at around 4.75 Hz.
Vibration (sweep)	ATA 300, (Jan 15/96) which states in Appendix II, B.4 This test also exceeds the specifications listed in MIL-STD-648C and may also fulfill ISO 8318 and ISO 2247	Vibration Test for Category I containers – Vibration tests shall be conducted on Category I containers in accordance with ASTM Designation D-999, Procedure B, within the range of 5 to 50 cycles per second for a period of not less than two (2) hours.
Simulated Rainfall	MIL-STD-810F, Method 506.4, Procedure II of 4.1.2 FED-STD-101C Method 5009.1, Sec 6.7.1	Four inches of rain per hour for 20 minutes each side. This was followed by a 4-hour test at 4" per hour on the top. Both tests saw the case heated to 18°F higher than the water temp.
Immersion	MIL-STD-810F, Method 512.4 FED-STD-101C	A 1-meter (3.281 feet) immersion for 1 hour with the case being heated to 40°F higher than the water temperature.

Storm Cases are more than just watertight, padlockable and **made in the USA**, they're also Unconditionally Guaranteed for Life.

**HARDIGG** **Hardigg® Cases** • 147 North Main Street, South Deerfield, MA 01373 • 800.542.7344 • stormcase.com  
**Hardigg® Europe** • Unit 4, Brookfield Industrial Estate, Leacon Road, Ashford, Kent TN23 4TU, UK • +44(0)1233 895895 • HardiggEurope.com



Trademarks owned by Hardigg Industries, Inc. ©Hardigg Industries, Inc. 2005 • Made in the USA.

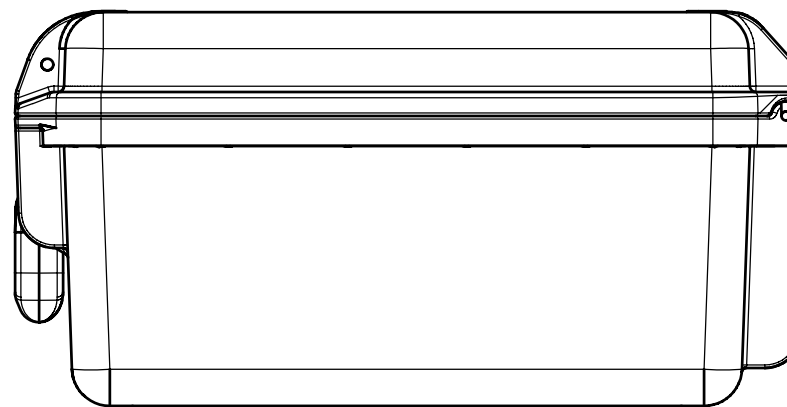
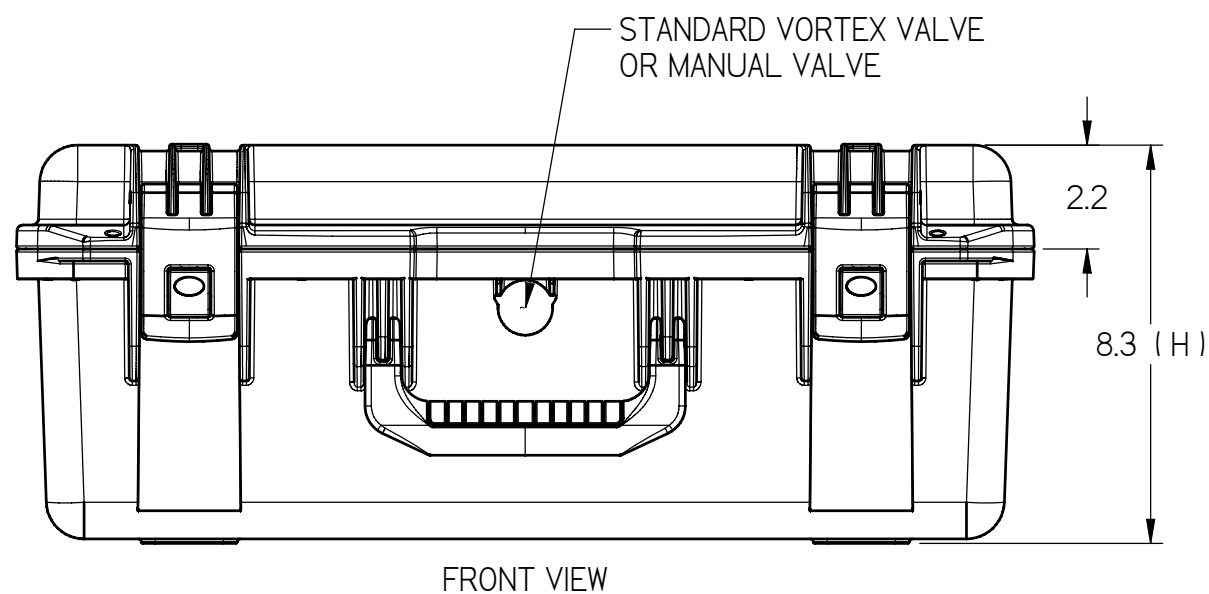
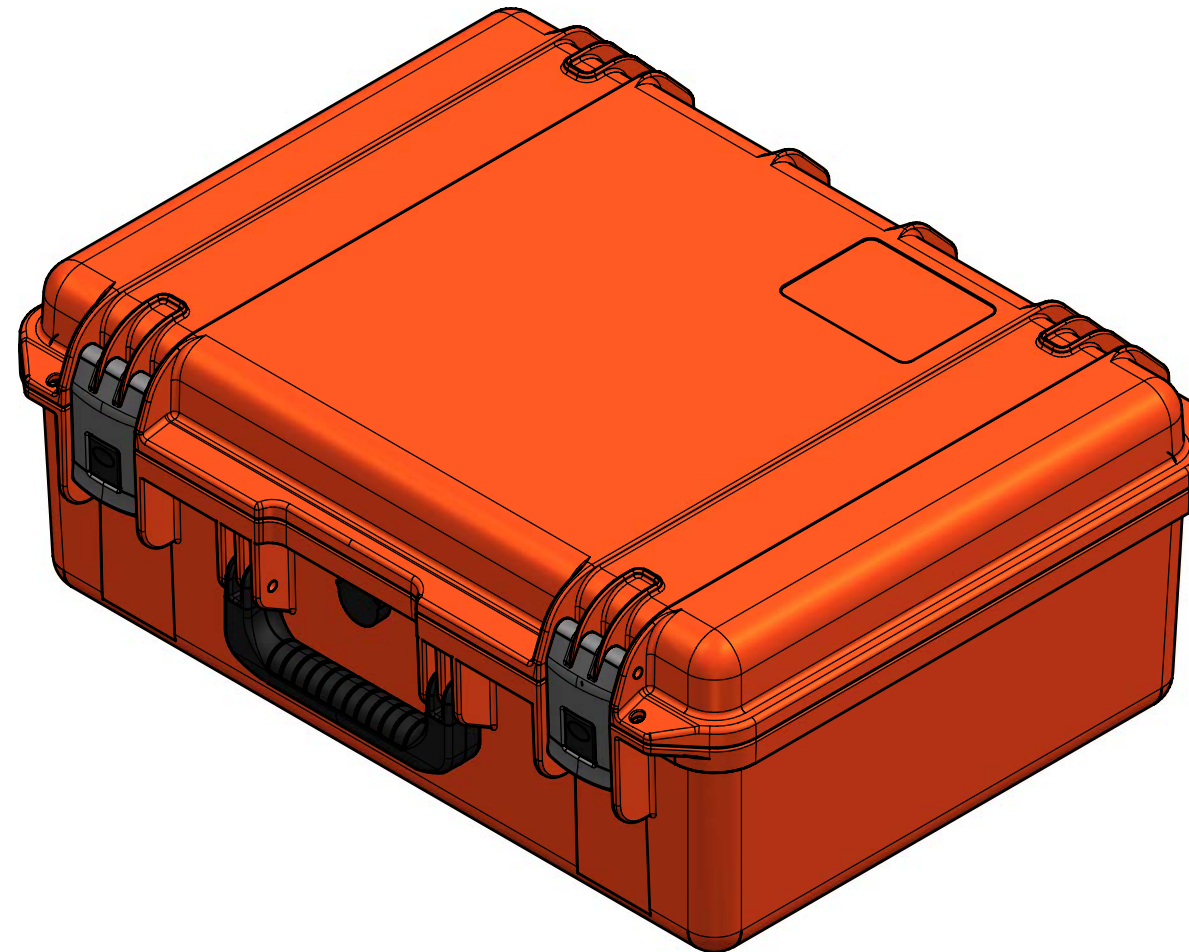
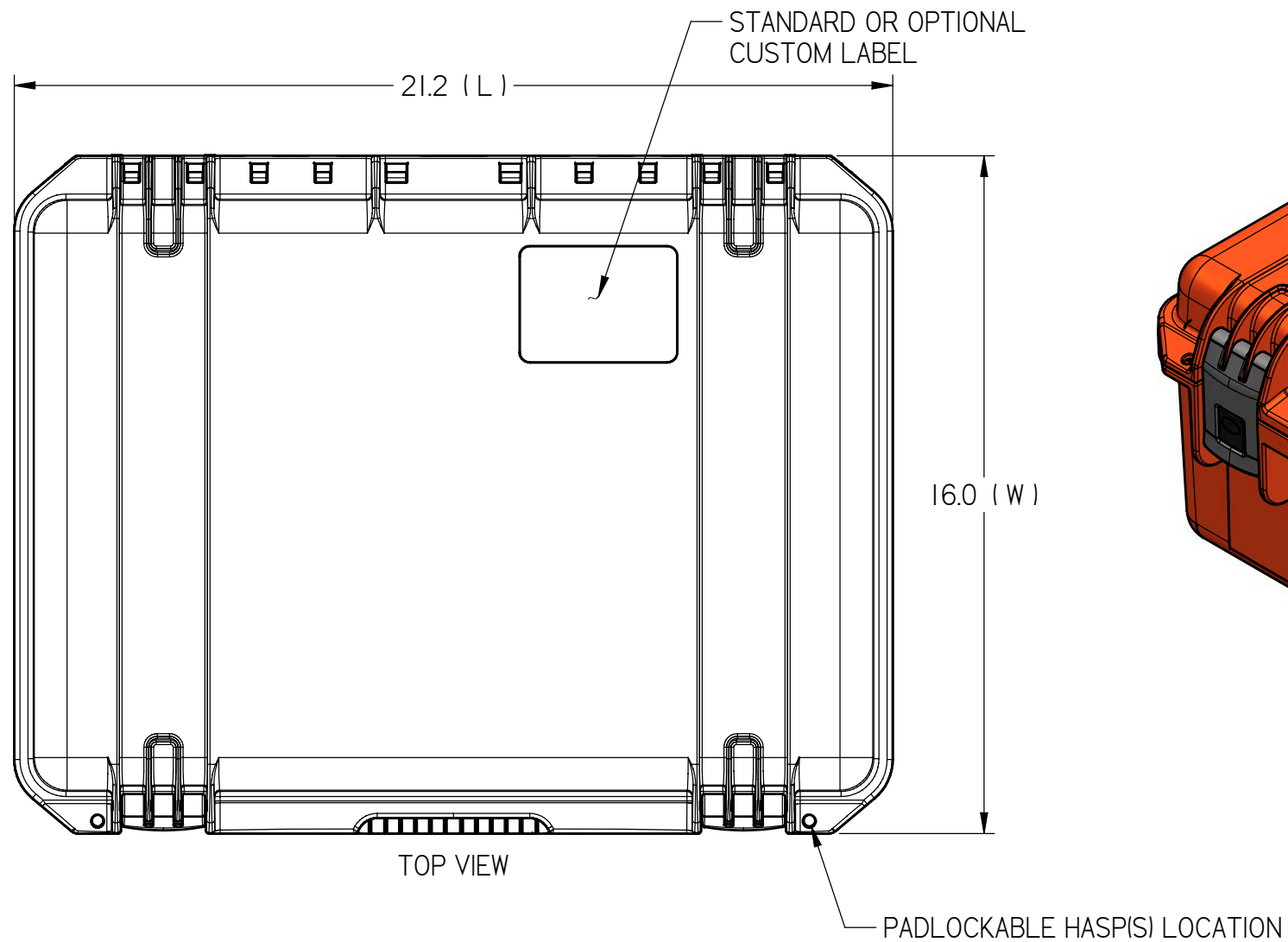

Model No.:	iM2600
Case Weight (lbs. Empty)	8.3 lbs.
Interior Length	20.0 in [508.0 mm]
Interior Width	14.0 in [355.6 mm]
Interior Height (overall)	07.7 in [195.6 mm]
Interior Lid Height	02.0 in [050.8 mm]
Exterior Length (L)	21.2 in [538.5 mm]
Exterior Width (W)	16.0 in [406.4 mm]
Exterior Height (H)	08.3 in [210.8 mm]
Master Pk. Qty.	2
Master Pk. Wt.	20.6 lbs

NOTES;  
 SEE STORM CASE LITERATURE FOR STANDARD CASE COLORS, CUSHION INTERIORS, AND P/N FOR ORDERING.  
**FOR REFERENCE ONLY**

RECOMMENDED MAX PAYLOAD 45 LBS

COMPUTER CONTROLLED DOCUMENT  
 MANUAL CHANGES NOT ALLOWED

This drawing and all copies and the design and data shown are the property of HARDIGG INDUSTRIES, INC. So. Deerfield, MA USA, and include proprietary information. The borrower by receipt or retention of the drawing agrees that, except as expressly authorized in writing by HARDIGG INDUSTRIES, INC. it will (1) not use the drawing or any copy of the design or data shown (2) not reproduce, copy, excerpt, exhibit or distribute the drawing or any copy for use by others and (3) upon demand return the drawing, all copies and all material copies therefrom.

147 North Main Street  
 P.O. Box 201  
 South Deerfield, MA  
 01373-0201 USA  
 T: 413-665-2163 or  
 800-542-7344  
 F: 413-665-8061  
<http://www.stormcase.com>



TITLE: Hardigg Storm Case

SIZE: D	CAGE CODE: 11214	Model No. iM2600	REV. -
Scale 1/2	Sht No. 1 of 1		