

**Standard features:**

- sturdy nylon snaps (2)
- durable living hinge opening
- A4 format (US letter)

**Technical specifications:**

- Material:** polypropylene
- Unit weight:** 1.1 lbs (0.5 kg)
- Qty per pack:** 12 units
- Pack weight:** 15 lbs (6.82 kg)
- Pack volume:** 1 cu. ft (0.028 m<sup>3</sup>)
- Colors available:** 001-Black  
035-Blue  
038-Red  
050-Mercury  
058-Graphite  
065-Navy  
067-Forest

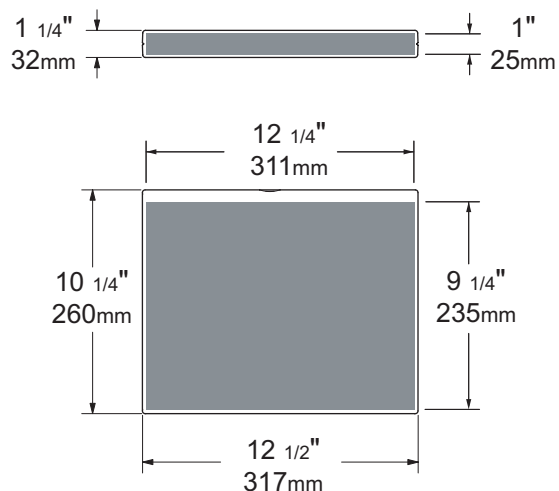
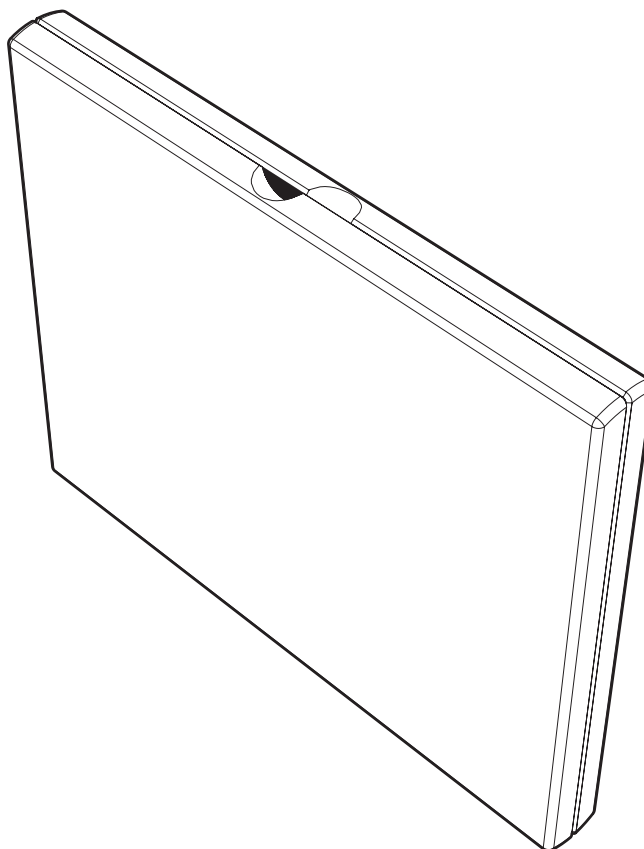

interior net usable space =