

Standard features:

- sturdy nylon latches (2)
- metal core hinges (2)

Technical specifications:

- Material:** polypropylene
- Unit weight:** 2.28 lb (1.03 kg)
- Qty per pack:** 8 units
- Pack weight:** 23 lbs (10.43 kg)
- Pack volume:** 5.96 cu. ft (0.169 m³)
- Colors available:** 001-Black
002-White
035-Blue
038-Red
050-Mercury
058-Graphite
065-Navy
067-Forest

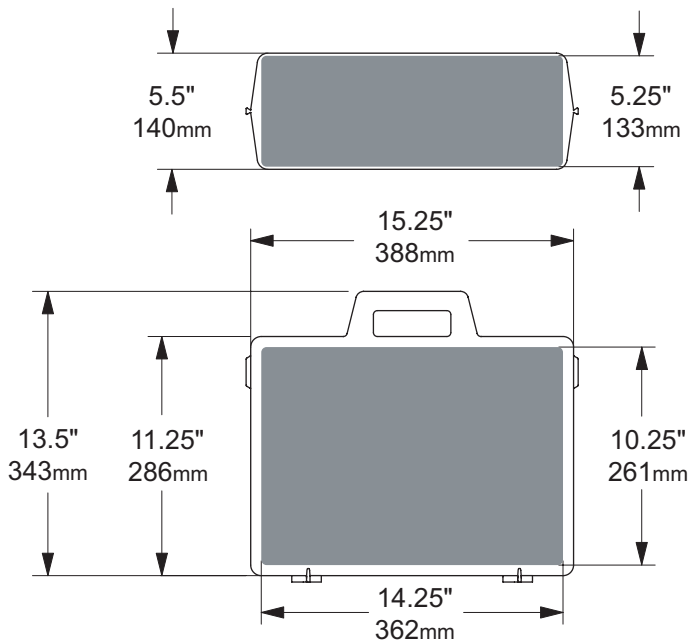
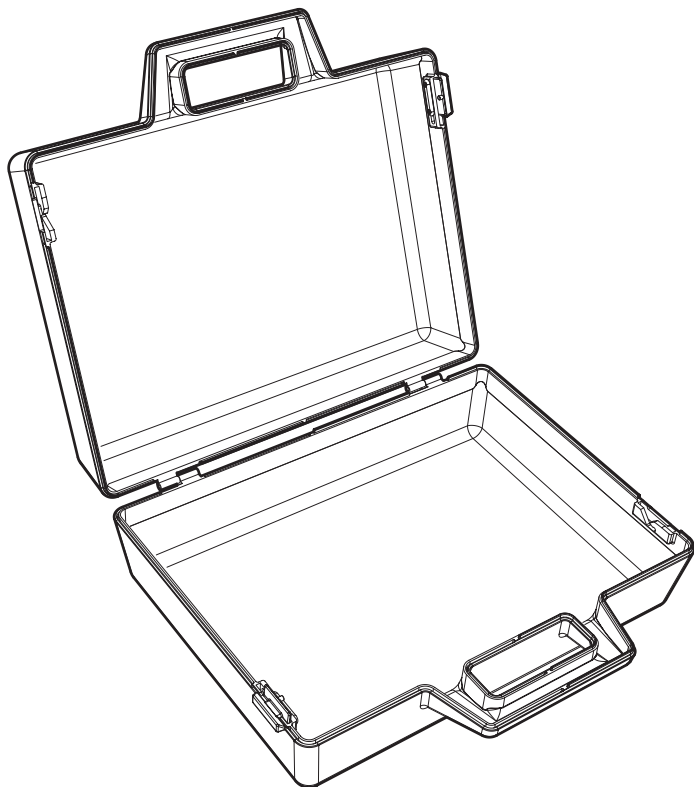
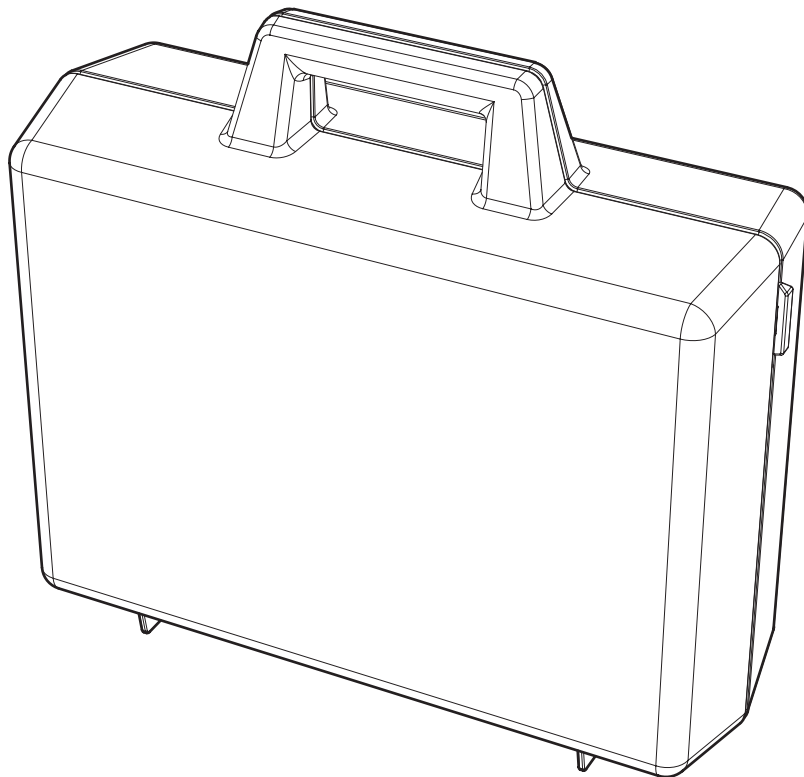

interior net usable space =