

Standard features:

- durable living hinge opening

Technical specifications:

- Material:** polypropylene
- Unit weight:** 0.32 lbs (0.145 kg)
- Qty per pack:** 24 units
- Pack weight:** 10 lbs (4.54 kg)
- Pack volume:** 2.0 cu. ft (0.057 m³)
- Colors available:** 001-Black
002-White
035-Blue
036-Yellow
037-Green
038-Red

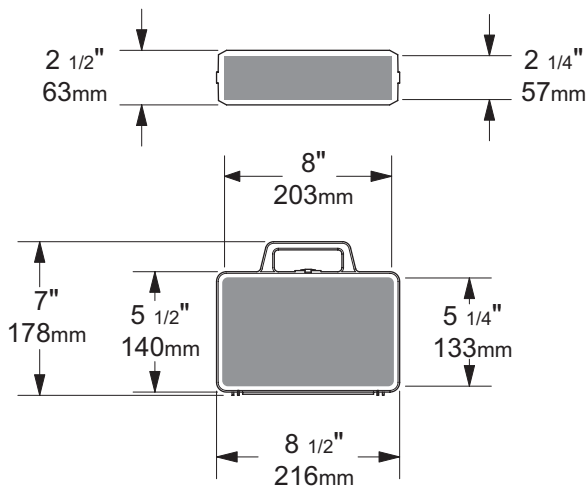
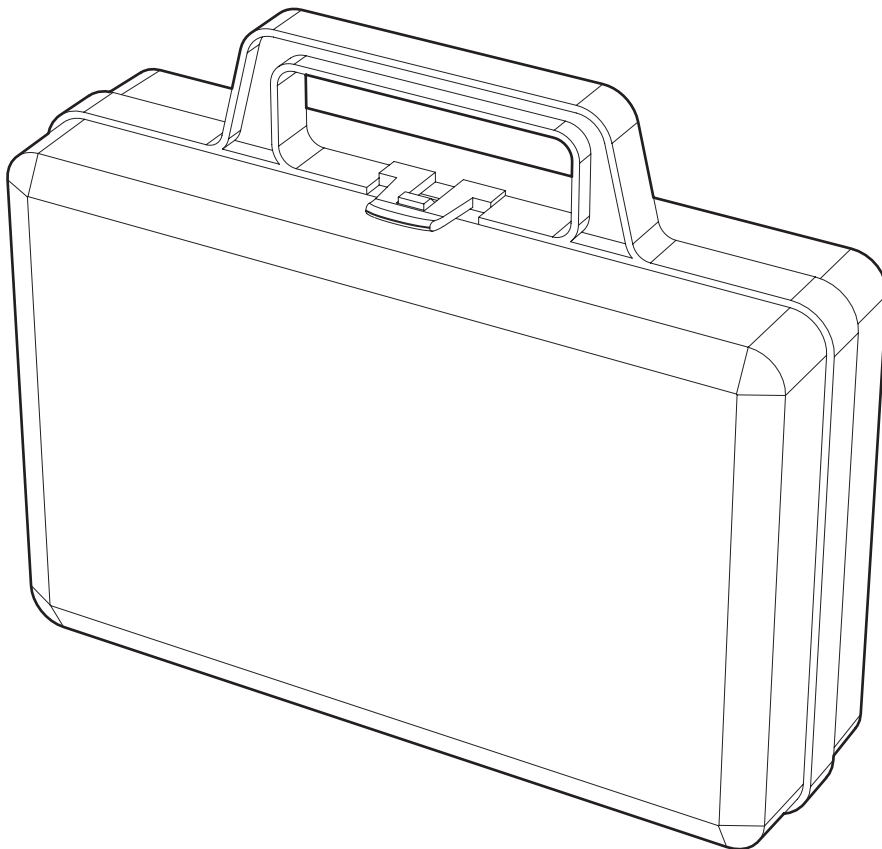

interior net usable space =